

SOLAR SMART

200 LITRE GAS - SOLAR SYSTEM

CHROMAGEN
Est. 1962
solar & energy solutions

GLOBAL LEADERS



Chromagen solar water heaters use the Sun's unlimited FREE energy to provide up to 80% of your hot water.

When these savings are combined with either State rebates, or the Federal Government initiated Renewable Energy Certificates Scheme, a Chromagen Solar Smart hot water system is the obvious economical choice.

Global Leaders

Chromagen is a Global Leader in the solar hot water industry. Founded in 1962, we have designed and manufactured a method of solar energy absorption, transfer and storage so advanced and effective, that we can boast of having over a million satisfied customers in over 40 countries around the world. Chromagen Solar Australia is a fully Australian owned company, staffed by a team of solar hot water experts with over 100 years combined experience. This ensures that you not only receive the highest quality products, Chromagen backs it up with high quality after sales service and support.

Aesthetically pleasing design, no more tank on the roof

Chromagen's Solar Smart water heaters consist of our high performance roof mounted solar collectors, matched with our range of high quality, technologically advanced ground mounted hot water storage tanks, matched with our high efficiency Eternity series gas boosters. A Chromagen Solar Smart system will not detract from the appearance of your home.

Never ending Steaming Hot water 24/7 – with Chromagen Solar / Gas

Chromagen's Solar Smart intelligent solar / gas design maximizes your solar savings by storing your solar heated water in our insulated, 200 litre, solar rated storage tank. This 'pre heated' water is then passed directly through our 5 & ½ Star rated Eternity series continuous flow gas water heater, which senses the incoming water temperature and adjusts the amount of gas used depending on how hot the incoming water is. The hotter the solar heated water – the less gas you use, ensuring you have never ending hot water 24 hours a day, 7 days week, at a cost that can be up to 80% lower than your current water heating bills.

Super Solar Smart Performance

The key to Chromagen's legendary performance and efficiency lies in our unique solar collector design. For example, independent testing shows that a Chromagen system with only one CR120 Black Chrome solar collector outperforms similar competitor products with two solar

collectors. Our larger solar collection area, ultrasonically welded all copper construction, and Black Chrome surface combine to produce a solar collector that is twice as efficient as the aluminium and steel black paint collectors used by a leading competitor.

Highest Quality – Highest Performance

Our range of Solar Smart water heaters are so efficient that they attract the highest government incentives, designed to encourage Australians to utilize our abundant solar energy resource. Plus – the quality of Chromagen Solar Smart systems is second to none – which is why we can offer a very attractive 7 year warranty. Add these two features together – super performance and long life – and the benefits equal higher savings on running costs over a longer life cycle.

Your local Dealer / Distributor is:

Accent Controls Pty Ltd
Suite 102/79-83 Longueville Rd
Lane Cove NSW 2066

Ph: +61 2 8459 7030
Email: info@accentcontrols.com.au
www.accentcontrols.com.au

Chromagen Pty Ltd

☎ 1300 367 565

www.chromagen.com.au



SYSTEM SPECIFICATIONS

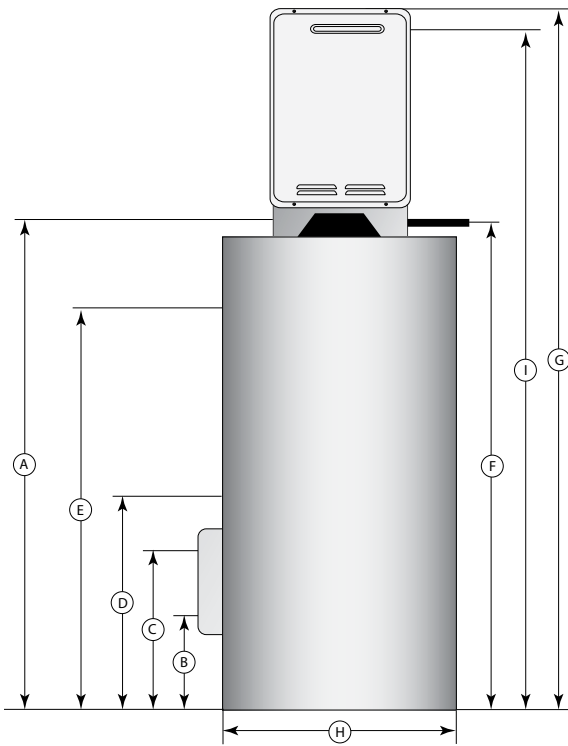

Tank	Description	200 litre
A (mm)	Hot water outlet	1260
B (mm)	Cold water inlet	290
C (mm)	Collector cold flow line	415
D (mm)	Collector hot return line	615
E (mm)	Pressure/Temperature Valve	940
F (mm)	20mm Gas line	1255
G (mm)	Height	1870
H (mm)	Width	600
I (mm)	Flue Terminal	1810
Weight	Kilograms (empty)	95

Collector	Length mm	Width (mm)	Weight Empty Kg	Weight Full Kg
CR100	1900	1090	39	42
CR120	2190	1290	51	56

Specifications are subject to change without notice.

